

Rev.	Date	ECN No.	Comment	Title
0	12/14/2018	E-1162	Initial Release	2016 Rebound Damping Upgrade

Scope

Customer instructions for installation and modification of struts to accept 2016 version of rebound damping upgrade.

Procedure

1 Disassembly

- 1.1 With strut in upright position, vent all pressure, upper chamber first, then lower chamber.
- 1.2 Secure strut upside-down in soft vise jaws clamped onto piston shaft at least 1-1/2" below end of shaft to avoid pinching lower mount threads.
- 1.3 Use impact to remove lower mount assembly. Some parts might unscrew and remain inside piston shaft. Drain oil and any loose parts.
- 1.4 Check bottom-side inside configuration of aluminum piston to ensure it will accept the current design lower mount assembly. Struts shipped beginning January 2016 should be current design. Either modify or replace piston to agree with 2016 current design.

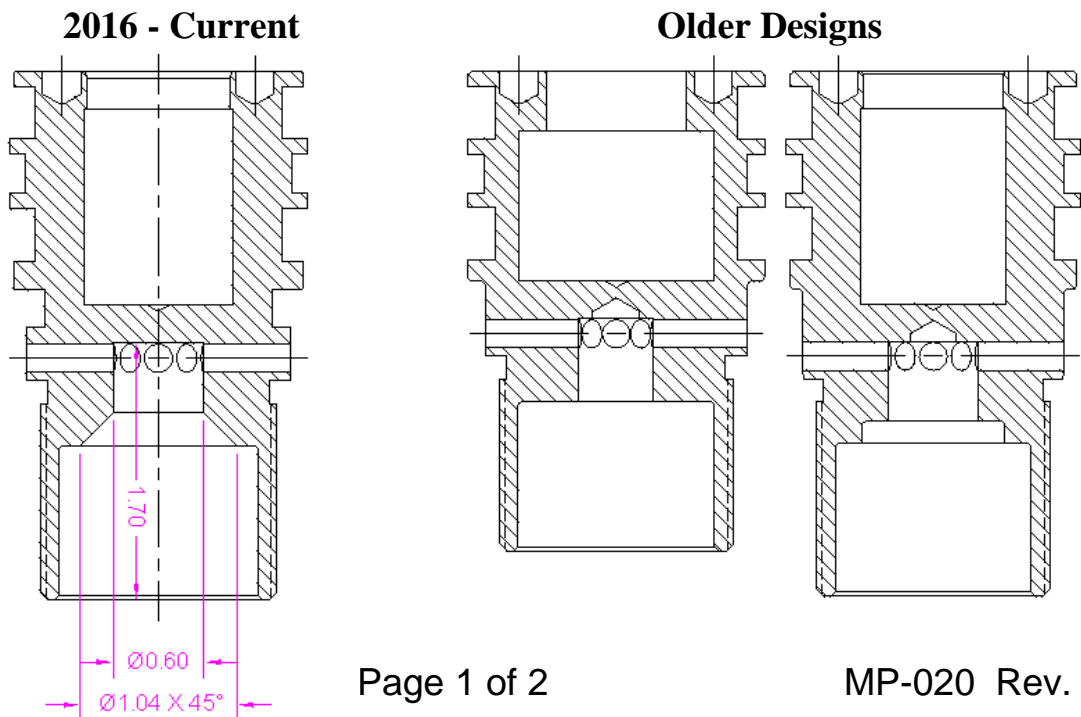

Rev.	Date	ECN No.	Comment	Title
0	12/14/2018	E-1162	Initial Release	2016 Rebound Damping Upgrade

2 Assembly

- 2.1 If previously removed, install piston into piston shaft with 1" long bead of blue medium strength #242 Loctite applied close to end of threads where shown. Secure piston with light impact. Allow to set 30 minutes before adding oil.
- 2.2 With strut upside-down in vise, install floating valve and spring assembly.

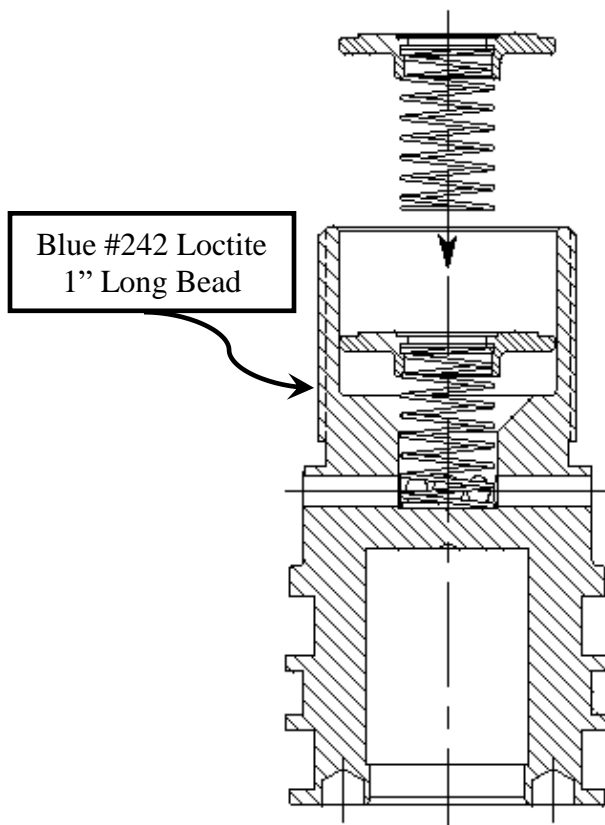

Stroke Length	Oil Fill (cc) 5w Oil
8	170
10	220
12	270
14	320
16	370
18	420
20	470
22	520
24	570

- 2.3 Add proper amount of 5w suspension oil into piston shaft.
- 2.4 Install lower mount assembly into piston shaft and torque with impact.

END